



# Biometrical genetics

David M. Evans\*, N.A. Gillespie, N.G. Martin

*Queensland Institute of Medical Research and Joint Genetics Program, PO Royal Brisbane Hospital,  
University of Queensland, Brisbane 4029, Australia*

---

## Abstract

Biometrical genetics is the science concerned with the inheritance of quantitative traits. In this review we discuss how the analytical methods of biometrical genetics are based upon simple Mendelian principles. We demonstrate how the phenotypic covariance between related individuals provides information on the relative importance of genetic and environmental factors influencing that trait, and how factors such as assortative mating, gene-environment correlation and genotype-environment interaction complicate such interpretations. Twin and adoption studies are discussed as well as their assumptions and limitations. Structural equation modeling (SEM) is introduced and we illustrate how this approach may be applied to genetic problems. In particular, we show how SEM can be used to address complicated issues such as analyzing the causes of correlation between traits or determining the direction of causation (DOC) between variables. © 2002 Elsevier Science B.V. All rights reserved.

*Keywords:* Structural equation modeling; Genetics; Mendelian principles; Twin studies

---

## 1. Introduction

The laws of genetics formulated by Gregor Mendel in the 19th century described the inheritance of discontinuous traits which exhibited clear patterns of segregation (e.g. green vs. yellow peas). However, most of the phenotypes relevant to biological psychology are quantitative traits characterized by continuous distributions which do not display clear-cut patterns of inheritance (e.g. blood pressure, skin conductance). It is important to realize that these traits are also subject to the same laws which govern the inheritance of 'Mendelian' phenotypes. Biometrical

---

\* Corresponding author. Tel.: +61-7-3362-0286; fax: +61-7-3362-0101  
E-mail address: [davide@qimr.edu.au](mailto:davide@qimr.edu.au) (D.M. Evans).

genetics is the field of science which deals with the inheritance of these continuous phenotypes.

## 2. Polygenic theory of quantitative traits

Quantitative traits are typically due to the combined action of several genetic loci (for a definition of these terms see the article by Slagboom in this volume). Segregation at multiple loci results in several categories of progeny. As the number of loci influencing the trait increases, the number of separate phenotypic categories increases, and the overall distribution of classes approaches normality. Superimposed upon this genetic variation are environmental effects which blur the demarcation between the individual classes causing the overall distribution to appear continuous. This makes it more difficult (though not impossible) to study the individual effects of genes influencing quantitative traits (Martin et al., 1997). However, if a trait of interest is normally distributed (or may be transformed to approximate a normal distribution), it is possible to make use of statistical approaches based upon the properties of the normal curve. In particular, by examining the covariance between different groups of relatives, it is possible to estimate the relative proportions of phenotypic variance resulting from genetic and environmental influences (Fisher, 1918; Mather and Jinks, 1982).

## 3. Partitioning the phenotypic variance

A phenotypic value is simply a measure of an individual's phenotype on an arbitrary scale. The phenotypic value ( $P$ ) is determined by contributions from the genotype and the environment:

$$P = G + E$$

where  $G$  is the genotypic value and  $E$  the environmental deviation. It is assumed that  $E$  is measured in deviation form (i.e. has a mean value of zero) so that the average phenotypic value equals the average genotypic value.

Fisher (1918) was first to demonstrate that it is possible to partition the genotypic value into additive and dominance components. This partitioning is illustrated for a single autosomal biallelic locus (Fig. 1), although the results may be generalized to multiple alleles and loci (Crow and Kimura, 1970; Kempthorne, 1957; Lynch and Walsh, 1998). The measurable effects of the genotypes at this locus are quantified by parameters known as genotypic effects. The genotypic effect of the homozygote  $A_1A_1$  is  $+a$  and the genotypic effect of  $A_2A_2$  is  $-a$ . The genotypic effect of the heterozygote  $A_1A_2$  depends upon the degree of dominance at the locus and is quantified by the parameter  $d$ . When there is no dominance ( $d = 0$ ), then alleles  $A_1$  and  $A_2$  are said to act additively in that the genotypic effect of the heterozygote is exactly half the sum of the genotypic effect of the two homozygotes. When  $d > 0$ ,

Genotype	A <sub>2</sub> A <sub>2</sub>	A <sub>1</sub> A <sub>2</sub>	A <sub>1</sub> A <sub>1</sub>
Genotypic Effect	- a	0	+ a
Genotypic Frequency	q <sup>2</sup>	2pq	p <sup>2</sup>

Fig. 1. A biallelic autosomal locus in a randomly mating population. The genotypic effect of the homozygotes A<sub>1</sub>A<sub>1</sub> and A<sub>2</sub>A<sub>2</sub> are +a and -a, respectively. The genotypic effect of the heterozygote A<sub>1</sub>A<sub>2</sub> is *d*, which is the degree of dominance at the locus. The gene frequencies of alleles A<sub>1</sub> and A<sub>2</sub> are *p* and *q*, respectively, and the frequencies of the genotypes are as shown.

allele A<sub>1</sub> displays dominance over allele A<sub>2</sub>. Conversely when *d* < 0 allele A<sub>2</sub> displays dominance over allele A<sub>1</sub>. When dominance is complete, *d* is equal to +a or -a.

The number of copies of a particular allele (e.g. allele A<sub>1</sub>) is referred to as the gene content. It is possible to regress gene content against genotypic value. Unless the alleles at the locus act additively there will exist a non-linear relationship between gene content and the genotypic value. This regression leads to a partitioning of the genotypic value into an expected value based on additivity at the locus, and a deviation based on dominance. The proportion of variance in the genotypic value explained by the regression is known as the additive genetic variance. It is the variance associated with the average additive effects of alleles and is the proportion of genetic variance transmitted from parent to offspring. The residual variance which is not explained by the regression is referred to as the dominance genetic variance and arises because of the non-linear interaction between alleles at the same locus.

In the case of the biallelic locus above, the additive ( $\sigma_A^2$ ) and dominance ( $\sigma_D^2$ ) components of variance are given by the formulae:

$$\sigma_A^2 = 2pq[(a + d(q - p))]^2$$

$$\sigma_D^2 = (2pqd)^2$$

Note that the additive genetic variance contains a contribution from the dominance parameter '*d*'. It is only when *d* = 0 or in the special case where the gene frequencies are equal does dominant gene action make no contribution to the additive genetic variance. In contrast, the dominance genetic variance will only contribute to the genetic variance when *d* > 0. Note also that both variance components depend critically upon the population allele frequencies *p* and *q*. Thus, a low proportion of dominance variance does not necessarily imply absence of dominant gene action, but rather may be a consequence of the particular allele frequencies in the population (Mather and Jinks, 1982).

In the case of a single locus, the total genetic variance is simply the sum of the additive and dominance components. The situation becomes more complicated when multiple loci are considered. In this case, the genetic variance may also contain an additional component of variance due to epistasis. Epistasis is the interaction between two or more different loci and may involve interactions between the additive

and/or dominance effects at those loci. Statistically speaking, epistatic variance is the residual genetic variance unexplained by the additive and dominance components. The interested reader is referred to any of the classic texts in quantitative genetics for a formal mathematical definition of epistatic variance (Crow and Kimura, 1970; Kempthorne, 1957; Lynch and Walsh, 1998; Mather and Jinks, 1982).

In the same way, it is also possible to partition the environmental variance into components due to shared environmental ( $\sigma_C^2$ ) and specific environmental ( $\sigma_E^2$ ) effects. Shared environmental influences are those which affect all members of a pedigree. For example, if we were studying blood pressure levels in adolescent twins, an example of a shared environmental factor might be dietary salt intake, since young twins living together are likely to have similar diets. In contrast, specific environmental influences are environmental effects which are unique to each member of the pedigree (e.g. measurement error).

Partitioning the variance into genetic and environmental components not only reveals the broad causes of individual differences in the phenotype, but also predicts the response of the population to certain processes. For example, the response of a population to natural selection is determined primarily by the additive genetic variance, whereas the deleterious effects of inbreeding arise through genetic dominance.

The amount of additive genetic variance expressed as a proportion of the total phenotypic variance is termed the narrow heritability of the trait (denoted by the symbol  $h^2$ ). The total amount of genetic variance (i.e. additive and dominance components) expressed as a proportion of the total phenotypic variance is called the broad heritability of the trait. Both types of heritability may range from zero (genetic differences are not responsible for individual differences in trait values) to one (all individual differences are due to the effect of genes). It is important to realize that like the genetic variance, broad and narrow heritabilities are population specific parameters, being functions of allele frequencies as well as genetic and environmental effects.

#### 4. Covariance between relatives

The different genetic and environmental variance components are typically estimated by examining the covariance between relative pairs. Genetic covariance between relations arises because relatives share some of their alleles identical by descent (when a pair of relatives receives the same allele from a common ancestor the alleles are said to be 'identical by descent'). Under several assumptions (e.g. random mating) the covariance between individuals  $x$  and  $y$  is given by:

$$\text{cov}(x, y) = 2\Theta_{xy}\sigma_A^2 + \Delta_{xy}\sigma_D^2 + \sigma_C^2$$

where  $T$  is the coefficient of kinship—the probability that an allele chosen at random from individual  $x$  at a particular locus will be identical by descent with an allele chosen at random from individual  $y$  at the same locus; and  $\Delta$  is the coefficient

of fraternity (Jacquard, 1974)—the probability that both alleles of both individuals at a locus are identical by descent (Cockerham, 1954; Fisher, 1918; Kempthorne, 1954). The covariance formula may be extended to include epistatic components of variance, although in human studies it is usually assumed that these components are small or absent because of the difficulties associated with resolving them reliably (see e.g. Eaves, 1988).

Note that the formula also contains a component due to the shared environment ( $\sigma_C^2$ ). In other words, phenotypic similarity between relatives also arises because relatives share similar environments. In human populations the only way to disentangle the contribution of genes and environment is by using study designs involving twins or adopted individuals.

## 5. Study designs

### 5.1. Twin studies

The classical twin design which compares the similarity of monozygotic (MZ) twins to that of dizygotic (DZ) twins is one of the most powerful study designs for estimating the relative contribution of genes and environment to human traits (Martin et al., 1978). Since MZ twins share all their genes in common, whereas DZ twins share on average half their genes, any excess similarity of MZ twins over DZ twins is the result of genetic factors. The design can also be used to detect the presence of common environmental influences affecting a trait (Jinks and Fulker, 1970), ‘sibling effects’ (Eaves, 1976)-individual differences which arise from the interaction between siblings, and ‘sex-limitation effects’ (Eaves et al., 1978)-differences in gene expression between the sexes.

The chief limitation of the method is that dominant genetic and common environmental components of variance cannot be estimated simultaneously since these components are negatively confounded in a study of twins reared together (Martin et al., 1978). This is because genetic dominance acts to inflate the correlation between MZ twins relative to the correlation between DZ twins, whereas common environmental effects inflate the correlation between DZ twins relative to the correlation between MZ twins. In order to illustrate this point formally, note that in the classical twin design information on the different variance components (i.e.  $\sigma_A^2$ ,  $\sigma_D^2$ ,  $\sigma_C^2$  and  $\sigma_E^2$ ) comes from three observed statistics, the phenotypic trait variance ( $\sigma_P^2$ ), the covariance between MZ twins ( $\text{cov}_{\text{MZ}}(x, y)$ ) and the covariance between DZ twins ( $\text{cov}_{\text{DZ}}(x, y)$ ):

$$\sigma_P^2 = \sigma_A^2 + \sigma_D^2 + \sigma_C^2 + \sigma_E^2$$

$$\text{cov}_{\text{MZ}}(x, y) = \sigma_A^2 + \sigma_D^2 + \sigma_C^2$$

$$\text{cov}_{\text{DZ}}(x, y) = 0.5\sigma_A^2 + 0.25\sigma_D^2 + \sigma_C^2$$

It is of course impossible to estimate four variance components using only three observed statistics. Expressing the covariance between DZ and MZ twins as a ratio leads to:

$$\frac{\text{cov}_{\text{DZ}}(x, y)}{\text{cov}_{\text{MZ}}(x, y)} = .5 \frac{\sigma_{\text{A}}^2}{\text{cov}_{\text{MZ}}(x, y)} + 0.25 \frac{\sigma_{\text{D}}^2}{\text{cov}_{\text{MZ}}(x, y)} + 1 \frac{\sigma_{\text{C}}^2}{\text{cov}_{\text{MZ}}(x, y)}$$

Note that this ratio is a weighted average of the terms one half, one quarter and one. If additive genetic effects are the only effects contributing to intrapair similarity, then the ratio would equal one half exactly. If the ratio is greater than one half, then  $\sigma_{\text{C}}^2$  must be involved (i.e.  $\sigma_{\text{C}}^2$  increases the ratio towards one). Conversely, if the ratio is less than one half,  $\sigma_{\text{D}}^2$  must be involved (i.e.  $\sigma_{\text{D}}^2$  decreases the ratio towards one quarter). Since at most only one of  $\sigma_{\text{C}}^2$  and  $\sigma_{\text{D}}^2$  can be estimated, the two parameters are negatively confounded. This is not to say that  $\sigma_{\text{C}}^2$  and  $\sigma_{\text{D}}^2$  cannot both contribute to the phenotypic variance of a trait, rather they cannot be estimated simultaneously with data from twins alone. As a consequence, when the correlation between MZ twins is less than twice the DZ correlation, we estimate  $\sigma_{\text{C}}^2$  and assume that genetic dominance is absent, and conversely when the MZ correlation is more than twice the DZ correlation we estimate  $\sigma_{\text{D}}^2$  and assume that  $\sigma_{\text{C}}^2$  is zero (Grayson, 1989).

Another criticism of the twin method is that twins differ from singletons in several important aspects, and therefore results derived from twin studies do not generalize to the rest of the population. For example, it has been well documented that twins have lower birth weights, experience shorter gestation times, and are at greater risk of perinatal complications and mortality than singletons (O'Brien and Hay, 1987; Petterson et al., 1993; Phillips, 1993). Several studies also report lower childhood IQs for twins compared with singletons (Record et al., 1970). However, most of these studies have examined young twins, and have not matched twins with singletons in terms of genetic or environmental backgrounds. Subsequently, a number of studies comparing older twins with singletons have failed to find differences in physical characteristics, cognitive abilities or in the prevalence of many adult diseases, suggesting that any differences between twins and singletons are 'washed out' early in development (Chitkara et al., 1988; Kendler et al., 1995; Nilsen et al., 1984; Posthuma et al., 2000).

The other major assumption of the classical twin study is the 'Equal Environments Assumption' that MZ twin pairs experience the same degree of environmental similarity as DZ twin pairs. If this is not the case, and MZ twin pairs are exposed to more similar environments than DZ pairs, then any excess similarity between MZ pairs compared with DZ pairs may be the result of environmental rather than genetic factors. There is strong evidence that MZ twins are treated more similarly than their DZ counterparts (Kendler et al., 1986). However, it is questionable whether this environmental similarity causes increased phenotypic concordance. Controlling for zygosity, environmental similarity, physical similarity and similarity of parental treatment during childhood does not predict twin similarity in personality, attitudes,

nor similarity in a range of cognitive variables (Kendler et al., 1993; Morris-Yates et al., 1990). A number of studies have examined the impact of actual versus perceived zygosity on trait similarity. If there is a preconceived notion that MZ twins are more alike than DZ twins (and therefore should be treated more similarly) then trait similarity should be a function of perceived zygosity. Studies using this method have failed to find any consistent influences of perceived zygosity on a range of psychological traits and conditions (Kendler et al., 1993). Thus it seems that the increased similarity in treatment of MZ twins is not due to their greater phenotypic similarity, but rather a consequence of their genetic identity and the more similar responses that this elicits from the environment.

It is possible to extend the classical twin design by including other informative relationships in the analysis including parents of twins (Eaves et al., 1978), the offspring of MZ twins (Nance and Corey, 1976), the offspring of MZ and DZ twins (Haley and Last, 1981), and the spouses of twins (Eaves, 1979; Heath and Eaves, 1985). These designs are exceedingly useful in that they are capable of resolving certain effects such as assortative mating and vertical cultural transmission which the classical twin study cannot (Eaves et al., 1978; Heath et al., 1985b; Jinks and Fulker, 1970). The twin study should therefore not be seen as an end in itself, but rather a starting point for investigation into other sorts of relationships.

## 5.2. Adoption designs

Adoption designs compare both genetically related individuals in uncorrelated environments and genetically unrelated individuals in correlated environments. Heath et al. (1985b) compared the power of a number of different adoption designs in a series of simulations. In general, the most powerful adoption designs involve gathering data from both biological parent and adopted away offspring and adoptive parent and adopted offspring pairs (Heath et al., 1985b). These designs are very powerful in detecting common environmental effects and are especially robust compared with extended twin kinship designs in resolving genetic and cultural inheritance in the presence of genetic dominance and assortative mating (Heath et al., 1985b).

All studies using adoptive individuals are subject to a number of limitations. It is assumed that placement is random in adoption designs—although it can be argued that this is seldom the case since adoptive families tend to be selected on the basis of their similarity to the biological parents and in many cases are related genetically to the child (e.g. an uncle or aunt). Adoptive parents also tend to be of good health and of higher socio-economic status than average. Adoption designs are also subject to generalizability problems in that results from adopted individuals may not be representative of the rest of the population since biological parents giving up children for adoption are unlikely to be a random sample of the population with respect to many traits of interest.

## 6. Factors precluding a simple decomposition of the phenotypic variance

Several factors may preclude a simple decomposition of the phenotypic variance in the manner described above. These include gene-environment interaction ( $G \times E$  interaction), gene-environment correlation ( $GE$  correlation) and assortative mating.

### 6.1. $G \times E$ interaction

$G \times E$  interaction occurs when genotypes differ in their sensitivity to environmental influences and is thus related to the statistical concept of heteroscedasticity, in that a single variance is inadequate to describe the variability of different genotypes.  $G \times E$  interaction may be directional (e.g. as the mean of a sub-group increases so does the variance) or unsystematic. In either case the effect is to increase the total phenotypic variance relative to the situation where such an interaction is absent (Jinks and Fulker, 1970). Analyses in experimental organisms (e.g. *Drosophila*) have demonstrated that  $G \times E$  interaction is a widespread phenomenon in many systems but seldom accounts for more than twenty percent of the total phenotypic variance (Eaves et al., 1977; Mather and Jinks, 1982). If the degree of  $G \times E$  interaction in man is similar to that in other organisms, then  $G \times E$  interaction represents an important source of variance which must be accounted for in any biometrical model of individual differences.

Data from MZ twins provide a unique opportunity to test for the presence of  $G \times E$  interaction in human populations. Jinks and Fulker (1970) suggested plotting the absolute intra-pair difference in MZ trait values against the corresponding intra-pair sum. Since MZ twins are genetically identical, their intra-pair difference can only be due to environmental effects unique to each twin. Conversely, the intra-pair sum provides an estimate of genetic effects (assuming of course that the trait itself is at least partially determined by genetic factors). A significant correlation between the two indicates the presence of  $G \times E$  interaction. The problem with the test is that it may also detect interaction between the common and unique environment. Ideally, the test should be supplemented with data from MZ twins reared apart to prevent this confounding (Jinks and Fulker, 1970). The Jinks-Fulker test will also not detect genetic control of environmental sensitivity if the genes involved are different from the genes contributing to the average value of the trait (Birley et al., 1997; Eaves et al., 1977; Jinks and Fulker, 1970; Martin, et al., 1983).

Once  $G \times E$  interaction has been detected it must either be controlled for statistically by altering the scale of measurement, or quantified. Any sort of systematic  $G \times E$  interaction (and indeed any form of systematic non-additivity) can be removed by a change of scale. The reason is that changing the scale of measurement alters the amount of information at different points in the scale and therefore the relative weighting of environmental factors given to each genotype (Eaves et al., 1977; Jinks and Fulker, 1970; Mather and Jinks, 1982).

It is possible to quantify the amount of  $G \times E$  interaction contributing to the phenotypic variance provided that the relevant environmental variable contributing to such an interaction is measured (Eaves et al., 1977; Neale and Cardon, 1992). In



this case it is necessary to obtain data from MZ and DZ pairs who are concordant for exposure to the variable of interest, concordant for non-exposure and discordant for exposure. It is then possible to determine whether the same set of genes affects the trait in different environments, and to quantify the magnitude of genetic effects in different environments. Measured genotypes may also be included in this design when it is possible not only to identify loci controlling environmental sensitivity (Birley et al., 1997), but also to estimate two way interactions between measured and residual genetic and environmental effects (Martin et al., 1987).

## 6.2. *GE correlation*

*GE* correlation refers to the non-random placement of genotypes within environments. *GE* correlation arises because the environment that an individual finds themselves in is ‘caused’ by the individual themselves or by their genetic relations. *GE* correlation may increase or decrease the total phenotypic variance depending on whether the correlation is positive or negative. Eaves et al. (1977) described three types of *GE* correlation which were classified according to their effect on the pattern of variances and covariances in the population: genotype–environment autocorrelation, sibling effects, and cultural transmission.

Genotype–environment autocorrelation occurs when an individual creates or evokes responses from the environment which are a function of their genotype. For example, children who are genetically intelligent may be more inclined to select environments conducive to learning. It is difficult to resolve this sort of *GE* correlation since it is difficult to know whether the genes affect the phenotype directly, or whether the environment produces differences originally caused by the genotype. Longitudinal or cross-cultural data may go some way to resolving this issue (Eaves et al., 1977; Neale and Cardon, 1992).

Sibling effects refer to *GE* correlation generated from the interaction between siblings. This form of covariance arises because the phenotype of a genetically related individual (in this case a sibling) provides part of the environment for the other sibling. Sibling effects may be cooperative, in that the trait value of one sibling increases the trait value of the other, or competitive, in which case the trait value of one sibling decreases the trait value of the other. Under favorable circumstances, sibling effects may be resolved through a comparison of MZ and DZ twins. Cooperative interactions increase the variances of MZ relative to DZ twins and increase the covariance between DZ twins relative to MZ twins, whereas competition interactions produce the opposite effects (Carey, 1986; Eaves, 1976; Eaves et al., 1978).

Cultural transmission arises because parents provide genes as well as environments to their offspring. An example of this type of *GE* correlation is the ‘Double Advantage Hypothesis’, that children who receive genes that increase their intellectual ability relative to average are also likely to be raised in homes that provide them with enriched environments (Jencks, 1972). The effect of cultural transmission may be modeled by analyzing the relationships between MZ and DZ twins and their parents. Such a design enables the common environmental variance

to be partitioned into components due to assortative mating, cultural transmission, gene-environment covariation and environmental effects shared by twins (Cardon et al., 1991).

### 6.3. Assortative mating

Assortative mating is non-random mating on the basis of anything other than biological relatedness. Phenotypic assortment is said to be positive when similar phenotypes mate together, and negative when mating occurs between dissimilar phenotypes. In human populations, assortment is almost universally positive being most marked for education (Heath et al., 1985a), religion (Truett et al., 1994), attitudes (Eaves et al., 1999) and socioeconomic status (Heath et al., 1987), is moderate for physical and cognitive traits (Vandenberg, 1972), and low or random for most personality variables (Eaves et al., 1999).

Since individuals who have similar phenotypes are also likely to share similar genotypes (assuming the trait is genetically influenced), mating between phenotypically similar individuals increases the proportion of homozygous progeny. Assortative mating also causes a build up of 'directional gametic phase disequilibrium' (Crow and Kimura, 1970), which simply means that alleles with like effects tend to assort together. These two factors produce an increase in the additive genetic variance, the magnitude of which depends upon the phenotypic correlation between mates, the heritability of the trait and the number of contributing loci (Crow and Kimura, 1970; Fisher, 1918). Positive assortative mating can also affect the dominance genetic variance component, but if the number of loci influencing the trait is large, this effect is not of practical significance (Fisher, 1918; Vetta, 1976). Positive assortment increases the additive genetic covariance between pairs of relatives, and in some types of relationship induces a dominance component to the covariance when there was none previously (Lynch and Walsh, 1998). Assortative mating may also produce a genotype-environment correlation since parents provide genes as well as the environment for their children (Eaves et al., 1977; Jencks, 1972). In the context of the classical twin study, positive assortment inflates the correlation between MZ and DZ twins by the same absolute amount, thus mimicking the effect of the shared environment.

Most models of assortative mating make a number of assumptions including that all individuals have an equal chance to reproduce (but see e.g. Wilson, 1973), and that assortment, genetic and cultural transmission remain constant across generations (i.e. a state of equilibrium has been reached). Under these assumptions it is possible to resolve the effects of assortative mating by analyzing the resemblance between MZ and DZ twins and their parents (Cardon et al., 1991). It is also possible to resolve the origin of the marital correlation by investigating other relationships. For example, by examining the correlation between spouse pairs longitudinally or by examining the spouses of related individuals, one can determine whether positive marital correlations arise from phenotypic assortment or as the result of interaction between spouses and convergence over time (Heath, 1987; Nance et al., 1981). Similarly a positive marital correlation between spouses may also arise because of

mate selection being based on similar social backgrounds rather than phenotypic similarity. This is referred to as social homogamy and may be an appropriate model to adopt when studying internal biological measures (Eaves et al., 1989; Heath and Eaves, 1985; Rao et al., 1974). The question can be addressed empirically by including the spouses of MZ and DZ twins in the analysis (Heath and Eaves, 1985).

## 7. Structural equation modeling

Structural equation modeling (SEM) is a flexible model-fitting approach used in the genetic analysis of twin and family data. SEM can be used to analyze the interaction between siblings (Eaves, 1976), sex-limitation effects (Eaves et al., 1978), the correlation between different variables (Martin and Eaves, 1977), longitudinal data (Boomsma and Molenaar, 1987), the direction of causation (DOC) between variables (Duffy and Martin, 1994), pedigrees of variable size (Dolan et al., 1999) and different types of relationship (Heath et al., 1985b). More recently, SEM has been used to perform combined linkage and association analyses while controlling for spurious associations (Fulker et al., 1999; Neale et al., 2000). SEM is possible via a number of user friendly software packages including LISREL (Jöreskog and Sörbom, 1989), EQS (Bentler, 1989) and Mx (Neale, 1997), the last of which being particularly suited to the analysis of genetically informative data. Raw data methods (in which the likelihood of the model is calculated directly from the raw data rather than from covariance matrices) have been incorporated into the Mx package (Lange et al., 1976; Neale, 1997). This means that pedigrees which contain incomplete data may be included in the analysis, avoiding the listwise deletion of cases which would occur if covariance matrices were analyzed.

In SEM the relationship between several latent unobserved and observed variables is summarized by a series of structural equations. In a genetic analysis, these equations relate the observed phenotype to latent genetic and environmental variables (i.e. the additive and dominant effects of genes etc.), and specify the correlation between the latent genetic and environmental factors. From these equations it is possible to derive the covariance matrix implied by the model through the use of covariance algebra (Bollen, 1989).

Alternatively, structural equation models may be represented diagrammatically using path diagrams (see Fig. 2). Path diagrams are mathematically complete descriptions of structural equations in that all relations between observed and latent variables are represented. Dependent variables are represented by square boxes, whereas independent variables are represented by circles. Causal paths between variables are represented by unidirectional arrows, correlations between variables are represented by bi-directional arrows. The strength of association between each variable is measured by a path coefficient (equivalent to a partial regression coefficient) in the case of a causal path, or a correlation coefficient in the case of a bi-directional path. Many researchers find path diagrams easier to understand than sets of structural equations. The expected covariance matrix implied by the model can be derived through the rules of path analysis (see e.g. Neale and Cardon, 1992).

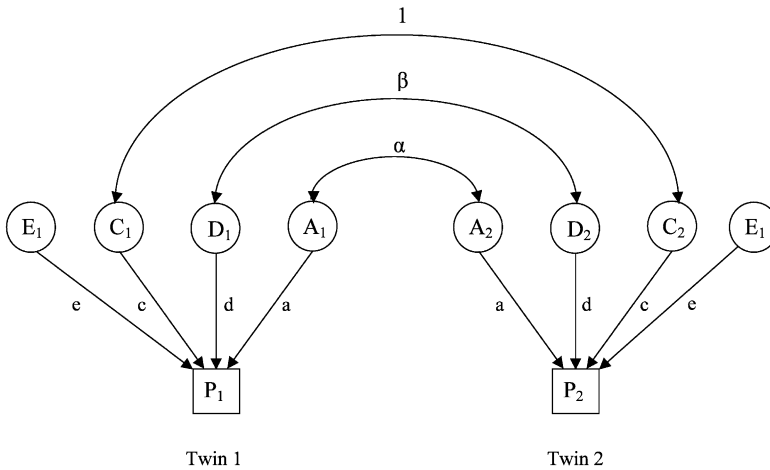

Fig. 2. Path diagram for MZ and DZ twins measured on a single phenotype. Each phenotype ( $P_1$ ,  $P_2$ ) is caused by a linear combination of latent additive genetic (A), dominant genetic (D), common environmental (C) and unique environmental (E) variables. Each latent variable is standardized (i.e. has a mean of zero and a variance of one) and the path coefficients of each latent variable on the observed phenotypes are estimated (i.e. a, d, c, e). From biometrical genetics theory, the additive genetic correlation between pairs ( $\alpha$ ) is 1 for MZ twins, and 0.5 for DZ twins. The correlation between dominance variance components ( $\beta$ ) is 1 for MZ twins, and 0.25 for DZ twins. The correlation between common environmental effects is one for MZ and DZ twins by definition.

Parameter estimates for the structural equation models are obtained by using a fitting function which quantifies the difference between the observed covariance matrix and the covariance matrix implied by the model. These functions provide a measure of how well the model fits the data as well as the significance of each of the model parameters. This ensures that the models employed adequately describe the data and each of the parameters is necessary.

## 8. Using SEM to analyze the correlation between twins

One simple application of SEM is in the analysis of MZ and DZ twins measured on a single trait to provide estimates of the genetic and environmental components of variance influencing that trait (e.g. Fig. 2). As was mentioned previously, it is impossible to simultaneously estimate common environmental and dominance variance components in a study of MZ and DZ twins reared together. Rather when the correlation between MZ twins is greater than twice the DZ correlation, we fit a model containing additive genetic, dominant genetic and unique environmental variance components (i.e. an ADE model) to the data, and when the MZ correlation is less than twice the DZ correlation, we fit a model containing additive genetic, common environmental and unique environmental variance components (i.e. an ACE model). The significance of each variance component may be assessed by

dropping the component from the full model and comparing the difference in fit between the two models. A non-significant decrease in fit indicates that the relevant variance component does not contribute significantly to variation in the trait and may be dropped from the model. In this way, it is possible to obtain estimates of the different variance components affecting the trait (and thus the narrow heritability of the trait) as well as a formal test of their significance.

## 9. Using SEM to analyze the correlation between variables

Just as SEM can be used to analyze the components of variance influencing a single variable, SEM can also be used to analyze the sources and structure of covariation underlying multiple variables (Martin and Eaves, 1977). In this case information not only comes from the covariance between the variables, but also from the cross-twin cross-trait covariances. In particular, a larger cross-twin cross-trait correlation between MZ twins as compared with DZ twins suggests that covariance between the variables is partially due to genetic factors.

A typical starting point in a multivariate analysis is to fit a full Cholesky model to the data (Fig. 3a). In this model the relationship between  $n$  variables is parameterized in terms of  $n$  factors, where all variables load on the first factor,  $n-1$  variables load on the second factor and so on, until the final variable loads on the  $n$ th factor only. Each source of phenotypic variation (i.e. A, C or D, and E) is parameterized in such a way. The pattern of factor loadings on the genetic and environmental factor structures reveals the etiology of covariation between the phenotypes (Martin and Eaves, 1977).

The Cholesky model can also be compared with more restrictive models such as the independent pathways and common pathway models which make strong theoretical predictions about the causes of covariation between phenotypic measures (Kendler et al., 1987; McArdle and Goldsmith, 1990). The independent pathways model assumes that covariation between phenotypes is due to the influence of common latent genetic ( $A_C$ ) and environmental factors ( $C_C$ ,  $E_C$ ). Residual variance specific to each variable is parameterized as specific latent genetic and environmental factors (Fig. 3b). The even more restrictive common pathways model assumes that both genes and environment contribute to an intermediate latent variable, which in turn is responsible for the observed pattern of covariation between the measures (Fig. 3c). Again, residual variation specific to each variable is parameterized by specific latent genetic and environmental factors. These models may be tested against one another and the Cholesky model to see which provides the most parsimonious fit to the observed data.

## 10. Using SEM to model the direction of causation

In many cases, experimental manipulation is not a possibility when investigating the DOC between psychological variables, so alternative approaches are needed.

(A) Cholesky Model

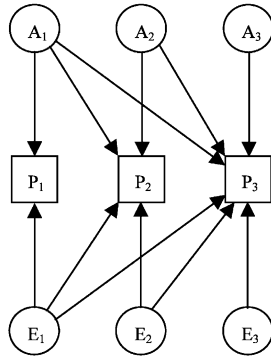

(B) Independent Pathways Model

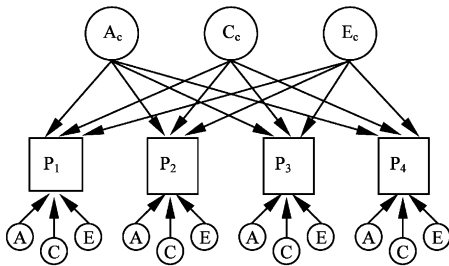

(C) Common Pathways Model

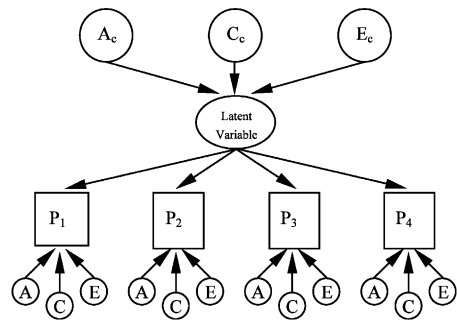

Fig. 3. Cholesky (A), independent pathways (B) and common pathway (C) models. In the case of the Cholesky model only structures for additive genetic and specific environmental factors are shown. All figures are drawn for one twin only.

Longitudinal or two-wave data designs, while potentially informative, are not without their disadvantages including stringent methodological requirements and the cost and time required for data collection (Heath et al., 1993; Neale et al., 1994). An alternative approach is to model DOC based on pairs of relatives measured on a single occasion (Duffy and Martin, 1994; Heath et al., 1993; Neale et al., 1994). When modeled using genetically informative data such as twins, the pattern of cross-twin cross-trait correlations can under certain conditions falsify strong hypotheses about the DOC between two variables provided several assumptions are satisfied: (i) that members of a twin pair are not having any mutual effect on one another i.e. sibling cooperation/rivalry, either within or across variables; (ii) the relationship between the two target variables is equivalent for twin 1 and twin 2; (iii) twin-pair correlations are different between target variables; and (iv) there are no unmeasured variables which influence both measures and thereby inflate the correlations arising through the causal influence of one variable on the other (Duffy and Martin, 1994; Neale et al., 1994). Assumption (iii) is critical since the power to detect DOC will be

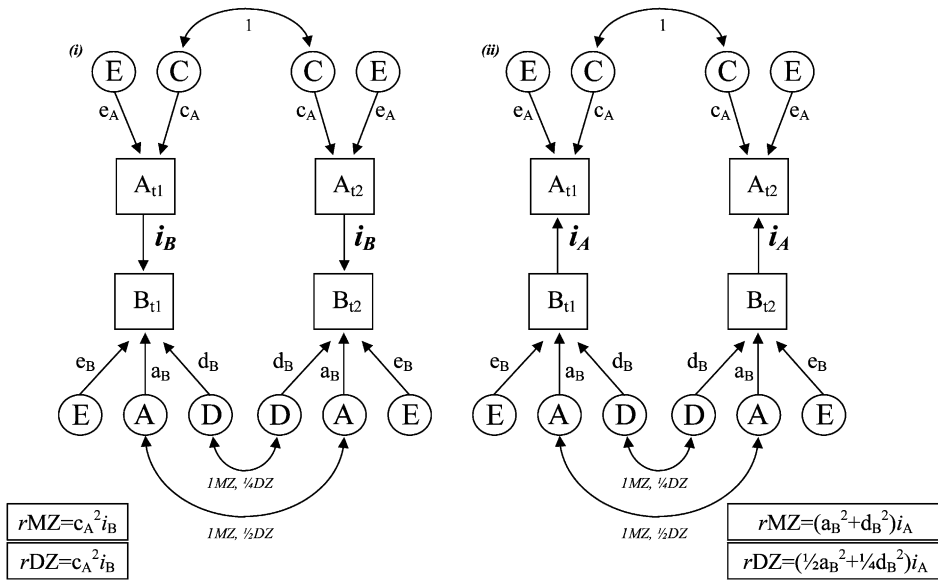

Fig. 4. Uni-directional causation hypotheses between two variables A and B, measured on a pair of twins: (i) trait A causes trait B and (ii) trait B causes trait A. Example based on simplified model of causes of twin pair resemblance in Neale and Cardon (1992). In the boxes are given the expected cross-twin cross-trait correlations for MZ and DZ twins under each uni-directional hypothesis. All latent variables are standardized to unit variance.

greatest when the genetic and environmental etiologies of the target variables are qualitatively and quantitatively different (Heath et al., 1993).

Fig. 4 illustrates the logic behind DOC modeling. Let us assume that variable A is best explained by shared (C) and non-shared (E) environmental effects while variable B is best explained by additive genetic (A), dominant genetic (D) and non-shared (E) environment effects. Under the ‘A causes B’ hypothesis (i), the cross-twin cross-trait correlation (i.e.  $r_{A_{t1}B_{t2}}, r_{A_{t2}B_{t1}}$ ) is  $c_A^2 i_B$  for MZ and DZ twin pairs alike. However, under the ‘B causes A’ hypothesis (ii), the cross-twin cross-trait correlation would be  $(a_B^2 + d_B^2) i_A$  for MZ and  $(\frac{1}{2}a_B^2 + \frac{1}{4}d_B^2) i_A$  for DZ twin pairs. It is apparent that if variables A and B have identical modes of inheritance then the cross-twin cross-trait correlations will be equivalent for MZ and DZ twin pairs alike, regardless of the DOC, and the power to detect DOC will vanish.

DOC models have received little attention in the psychophysiological literature to date. This is a shame since such models could prove exceedingly useful in illuminating the relationship between psychological constructs and psychophysiological variables (e.g. the size and latency of ERP components and various aspects of cognition).

**11. Using SEM to analyze developmental change**

Changes in the magnitude of genetic and environmental effects over time may be quantified by cross-sectional studies that measure subjects of different ages. However, in order to assess whether the same genes and environmental influences affect a trait over time, longitudinal data from genetically informative subjects is required. One attractive possibility is to model data collected from MZ and DZ twins in terms of a genetic simplex model (Boomsma et al., 1989; Boomsma and Molenaar, 1987; Evans et al., 2001).

Simplex models (Fig. 5) are autoregressive models where the latent genetic or environmental variable at time  $i$  ( $\eta_i$ ) is causally related to the immediately preceding latent variable through a linear relation i.e.:

$$\eta_i = \beta_i \eta_{i-1} + \zeta_i$$

where  $\beta_i$  is the linear regression of the latent factor on the previous latent variable, and  $\zeta_i$  represents new input (innovation) at time ( $i$ ) which is uncorrelated with  $\eta_{i-1}$ . The innovations are that part of the latent factor at time ( $i$ ) that is not caused by the latent factor at time ( $i-1$ ), but are part of every subsequent time point. Structural

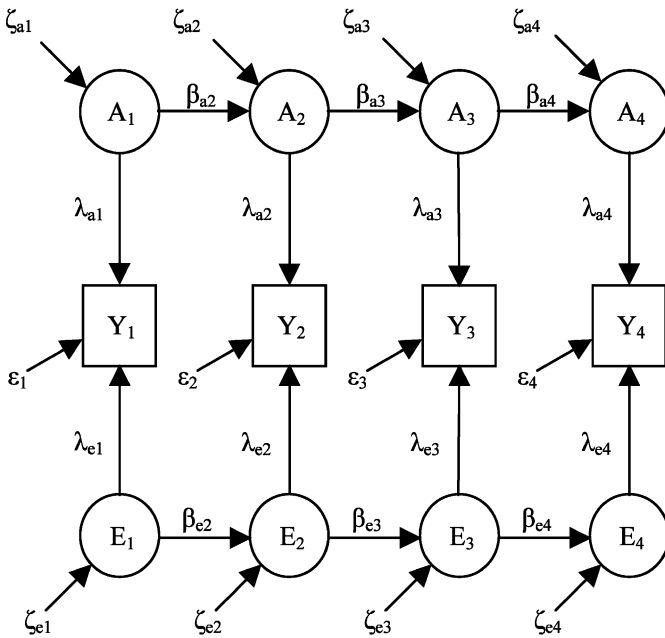

Fig. 5. Path diagram for a longitudinal genetic simplex model. Phenotypic variation is due to additive genetic (A), unique environmental (E) sources of variation as well as measurement error ( $\epsilon$ ). Variation in each latent variable is due to innovation ( $\zeta$ ) and also variance transmitted from previous occasions. The phenotypic covariation between the different time points is due solely to the transmission parameters ( $\beta$ ). Only structures for additive genetic (A) and specific environmental influences (E) are shown. The figure is drawn for one twin only.



equations of this type may be expressed for each latent genetic and environmental source of variation. Also part of the model is a structural equation relating the observed phenotypes to the latent factors:

$$y_i = \lambda_i \eta_i + \varepsilon_i$$

where  $\lambda_i$  is the factor loading of the observed phenotype on the latent variable at time (i), and  $\varepsilon_i$  is a measurement error term which affects the phenotype, but is uncorrelated with  $\eta_i$ . The question of whether different genes or environmental influences affect the trait at different ages can be investigated by dropping the relevant innovation from the full model and assessing whether the deterioration in the fit of the model is significant.

## 12. Conclusion

In conclusion, we have illustrated how the laws governing the inheritance of continuous traits are derived from basic Mendelian principles, and how twin and adoption studies can be used to decompose phenotypic variation into genetic and environmental components. We hope that we have given the reader an appreciation of the power and flexibility of the SEM approach and how it may be used to address more complicated questions than simply whether a trait is heritable. The interested reader is urged to consult one of the classic texts (Neale and Cardon, 1992) for a more detailed treatment of the subject.

## References

- Bentler, P.M., 1989. EQS: Structural Equations Program Manual. BMDP Statistical Software, Los Angeles.
- Birley, A.J., MacLennan, R., Wahlqvist, M., Gerns, L., Pangan, T., Martin, N.G., 1997. MN blood group affects response of serum LDL cholesterol level to a low fat diet. *Clin. Genet.* 51 (5), 291–295.
- Bollen, K.A., 1989. *Structural Equations with Latent Variables*. Wiley, New York.
- Boomsma, D.I., Molenaar, P.C., 1987. The genetic analysis of repeated measures. I. Simplex models. *Behav. Genet.* 17 (2), 111–123.
- Boomsma, D.I., Martin, N.G., Molenaar, P.C., 1989. Factor and simplex models for repeated measures: application to two psychomotor measures of alcohol sensitivity in twins. *Behav. Genet.* 19 (1), 79–96.
- Cardon, L.R., Fulker, D.W., Joreskog, K.G., 1991. A LISREL 8 model with constrained parameters for twin and adoptive families. *Behav. Genet.* 21 (4), 327–350.
- Carey, G., 1986. Sibling imitation and contrast effects. *Behav. Genet.* 16 (3), 319–341.
- Chitkara, B., Macdonald, A., Reveley, A.M., 1988. Twin birth and adult psychiatric disorder. An examination of the case records of the Maudsley Hospital. *Br. J. Psychiatry* 152, 391–398.
- Cockerham, C.C., 1954. An extension of the concept of partitioning hereditary variance for analysis of covariances among relatives when epistasis is present. *Genetics* 39, 859–882.
- Crow, J.F., Kimura, M., 1970. *An Introduction to Population Genetics Theory*. Harper and Row, New York, NY.
- Dolan, C.V., Boomsma, D.I., Neale, M.C., 1999. A note on the power provided by sibships of sizes 2, 3, and 4 in genetic covariance modeling of a codominant QTL. *Behav. Genet.* 29 (3), 163–170.

- Duffy, D.L., Martin, N.G., 1994. Inferring the direction of causation in cross-sectional twin data: theoretical and empirical considerations. *Genet. Epidemiol.* 11 (6), 483–502.
- Eaves, L., 1976. A model for sibling effects in man. *Heredity* 36 (2), 205–214.
- Eaves, L., 1979. The use of twins in the analysis of assortative mating. *Heredity* 43 (3), 399–409.
- Eaves, L.J., 1988. Dominance alone is not enough. *Behav. Genet.* 18 (1), 27–33.
- Eaves, L.J., Last, K., Martin, N.G., Jinks, J.L., 1977. A progressive approach to non-additivity and genotype–environmental covariance in the analysis of human differences. *Br. J. Math. Stat. Psychol.* 30, 1–42.
- Eaves, L.J., Last, K.A., Young, P.A., Martin, N.G., 1978. Model-fitting approaches to the analysis of human behaviour. *Heredity* 41 (3), 249–320.
- Eaves, L.J., Fulker, D.W., Heath, A.C., 1989. The effects of social homogamy and cultural inheritance on the covariances of twins and their parents: a LISREL model. *Behav. Genet.* 19 (1), 113–122.
- Eaves, L., Heath, A., Martin, N., Maes, H., Neale, M., Kendler, K., Kirk, K., Corey, L., 1999. Comparing the biological and cultural inheritance of personality and social attitudes in the Virginia 30 000 study of twins and their relatives. *Twin Res.* 2 (2), 62–80.
- Evans, D.M., Frazer, I.H., Boomsma, D.I., Martin, N.G., 2001. Developmental genetics of red cell indices during puberty: a longitudinal twin study. *Int. J. Hum. Genet.* 1 (1), 41–53.
- Fisher, R.A., 1918. The correlation between relatives on the supposition of Mendelian inheritance. *Trans. R. Soc. Edinburgh* 52, 399–433.
- Fulker, D.W., Cherny, S.S., Sham, P.C., Hewitt, J.K., 1999. Combined linkage and association sib-pair analysis for quantitative traits. *Am. J. Hum. Genet.* 64 (1), 259–267.
- Grayson, D.A., 1989. Twins reared together: minimizing shared environmental effects. *Behav. Genet.* 19 (4), 593–604.
- Haley, C.S., Last, K., 1981. The advantages of analysing human variation using twins and twin half-sibs and cousins. *Heredity* 47 (2), 221–236.
- Heath, A.C., 1987. The analysis of marital interaction in cross-sectional twin data. *Acta Genet. Med. Gemellol. (Roma)* 36 (1), 41–49.
- Heath, A.C., Eaves, L.J., 1985. Resolving the effects of phenotype and social background on mate selection. *Behav. Genet.* 15 (1), 15–30.
- Heath, A.C., Berg, K., Eaves, L.J., Solaas, M.H., Sundet, J., Nance, W.E., Corey, L.A., Magnus, P., 1985a. No decline in assortative mating for educational level. *Behav. Genet.* 15 (4), 349–369.
- Heath, A.C., Kendler, K.S., Eaves, L.J., Markell, D., 1985b. The resolution of cultural and biological inheritance: informativeness of different relationships. *Behav. Genet.* 15 (5), 439–465.
- Heath, A.C., Eaves, L.J., Nance, W.E., Corey, L.A., 1987. Social inequality and assortative mating: cause or consequence. *Behav. Genet.* 17 (1), 9–17.
- Heath, A.C., Kessler, R.C., Neale, M.C., Hewitt, J.K., Eaves, L.J., Kendler, K.S., 1993. Testing hypotheses about direction of causation using cross-sectional family data. *Behav. Genet.* 23 (1), 29–50.
- Jacquard, A., 1974. *The Genetic Structure of Populations*. Springer, New York, NY.
- Jencks, C., 1972. *Inequality: A Reassessment of the Effect of Family and Schooling in America*. Basic Books, New York.
- Jinks, J.L., Fulker, D.W., 1970. Comparison of the biometrical genetical, MAVA, and classical approaches to the analysis of human behavior. *Psychol. Bull.* 73 (5), 311–349.
- Jöreskog, K.G., Sörbom, D., 1989. *LISREL 7: A Guide to the Program and Applications*. SPSS, Chicago.
- Kempthorne, O., 1954. The correlation between relatives in a random mating population. *Proc. R. Soc. Lond. B* 143, 103–113.
- Kempthorne, O., 1957. *An Introduction to Genetic Statistics*. Wiley, New York, NY.
- Kendler, K.S., Heath, A., Martin, N.G., Eaves, L.J., 1986. Symptoms of anxiety and depression in a volunteer twin population. The etiologic role of genetic and environmental factors. *Arch. Gen. Psychiatry* 43 (3), 213–221.
- Kendler, K.S., Heath, A.C., Martin, N.G., Eaves, L.J., 1987. Symptoms of anxiety and symptoms of depression. Same genes, different environments. *Arch. Gen. Psychiatry* 44 (5), 451–457.
- Kendler, K.S., Neale, M.C., Kessler, R.C., Heath, A.C., Eaves, L.J., 1993. A test of the equal-environment assumption in twin studies of psychiatric illness. *Behav. Genet.* 23 (1), 21–27.

- Kendler, K.S., Martin, N.G., Heath, A.C., Eaves, L.J., 1995. Self-report psychiatric symptoms in twins and their nontwin relatives: are twins different. *Am. J. Med. Genet.* 60 (6), 588–591.
- Lange, K., Westlake, J., Spence, M.A., 1976. Extensions to pedigree analysis. III. Variance components by the scoring method. *Ann. Hum. Genet.* 39 (4), 485–491.
- Lynch, M., Walsh, B., 1998. *Genetics and Analysis of Quantitative Traits*. Sinauer Associates, Sunderland, MA.
- Martin, N., Boomsma, D., Machin, G., 1997. A twin-pronged attack on complex traits. *Nat. Genet.* 17 (4), 387–392.
- Martin, N.G., Eaves, L.J., 1977. The genetical analysis of covariance structure. *Heredity* 38 (1), 79–95.
- Martin, N.G., Eaves, L.J., Kearsley, M.J., Davies, P., 1978. The power of the classical twin study. *Heredity* 40 (1), 97–116.
- Martin, N.G., Rowell, D.M., Whitfield, J.B., 1983. Do the MN and Jk systems influence environmental variability in serum lipid levels. *Clin. Genet.* 24 (1), 1–14.
- Martin, N.G., Eaves, L.J., Heath, A.C., 1987. Prospects for detecting genotype  $\times$  environment interactions in twins with breast cancer. *Acta. Genet. Med. Gemellol. (Roma)* 36 (1), 5–20.
- Mather, K., Jinks, J.L., 1982. *Biometrical Genetics*. Chapman & Hall, New York, NY.
- McArdle, J.J., Goldsmith, H.H., 1990. Alternative common factor models for multivariate biometric analyses. *Behav. Genet.* 20 (5), 569–608.
- Morris-Yates, A., Andrews, G., Howie, P., Henderson, S., 1990. Twins: a test of the equal environments assumption. *Acta Psychiatr. Scand.* 81 (4), 322–326.
- Nance, W.E., Corey, L.A., 1976. Genetic models for the analysis of data from the families of identical twins. *Genetics* 83 (4), 811–826.
- Nance, W.E., Corey, L.A., Rose, R.J., Eaves, L.J., 1981. Relevance of the marriages of twins to the causal analysis of nonrandom mating. *Prog. Clin. Biol. Res.* 69 (Pt. B), 61–71.
- Neale, M.C., 1997. *Statistical Modelling*, fourth ed.. Department of Psychiatry, Medical College of Virginia, Richmond, VA.
- Neale, M.C., Cardon, L.R., 1992. *Methodology for Genetic Studies of Twins and Families*. Kluwer Academic Publishers, Dordrecht, The Netherlands.
- Neale, M.C., Walters, E., Heath, A.C., Kessler, R.C., Perusse, D., Eaves, L.J., Kendler, K.S., 1994. Depression and parental bonding: cause, consequence, or genetic covariance. *Genet. Epidemiol.* 11 (6), 503–522.
- Neale, M.C., de Knijff, P., Havekes, L.M., Boomsma, D.I., 2000. ApoE polymorphism accounts for only part of the genetic variation in quantitative ApoE levels. *Genet. Epidemiol.* 18 (4), 331–340.
- Nilsen, S.T., Bergsjø, P., Nome, S., 1984. Male twins at birth and 18 years later. *Br. J. Obstet. Gynaecol.* 91 (2), 122–127.
- O'Brien, P.J., Hay, D.A., 1987. Birthweight differences, the transfusion syndrome and the cognitive development of monozygotic twins. *Acta Genet. Med. Gemellol. (Roma)* 36 (2), 181–196.
- Pettersson, B., Nelson, K.B., Watson, L., Stanley, F., 1993. Twins, triplets, and cerebral palsy in births in Western Australia in the 1980s. *Br. Med. J.* 307 (6914), 1239–1243.
- Phillips, D.I., 1993. Twin studies in medical research [letter]. *Lancet* 342 (8862), 52.
- Posthuma, D., De Geus, E.J.C., Bleichrodt, N., Boomsma, D.I., 2000. Twin-singleton differences in intelligence. *Twin Res.* 3, 83–87.
- Rao, D.C., Morton, N.E., Yee, S., 1974. Analysis of family resemblance. II. A linear model for familial correlation. *Am. J. Hum. Genet.* 26 (3), 331–359.
- Record, R.G., McKeown, T., Edwards, J.H., 1970. An investigation of the difference in measured intelligence between twins and single births. *Ann. Hum. Genet.* 34 (1), 11–20.
- Truett, K.R., Eaves, L.J., Walters, E.E., Heath, A.C., Hewitt, J.K., Meyer, J.M., Silberg, J., Neale, M.C., Martin, N.G., Kendler, K.S., 1994. A model system for analysis of family resemblance in extended kinships of twins. *Behav. Genet.* 24 (1), 35–49.
- Vandenberg, S.G., 1972. Assortative mating, or who marries whom. *Behav. Genet.* 2 (3), 127–157.
- Vetta, A., 1976. Correction to Fisher's correlations between relatives and environmental effects. *Nature* 263 (5575), 316–317.
- Wilson, S.R., 1973. The correlation between relatives under the multifactorial model with assortative mating. I. The multifactorial model with assortative mating. *Ann. Hum. Genet.* 37 (2), 189–204.