

Lab Experiment # 14

Construction and verification of 4 bit ripple counter and mod 10/mod 12 ripple counter

Objective

To design and verify 4-bit ripple counter mod 10/ mod 12 ripple counter.

Parts required

S No.	COMPONENT	SPECIFICATION	QTY.
1.	JK FLIP FLOP	IC 7476	2
2.	NAND GATE	IC 7400	1

Theory

A counter is a register capable of counting number of clock pulse arriving at its clock input. Counter represents the number of clock pulses arrived. A specified sequence of states appears as counter output. This is the main difference between a register and a counter. There are two types of counter, synchronous and asynchronous. In synchronous common clock is given to all flip flop and in asynchronous first flip flop is clocked by external pulse and then each successive flip flop is clocked by Q or Q output of previous stage. As soon the clock of second stage is triggered by output of first stage. Because of inherent propagation delay time all flip flops are not activated at same time which results in asynchronous operation.

Pin Diagram for IC 7476:

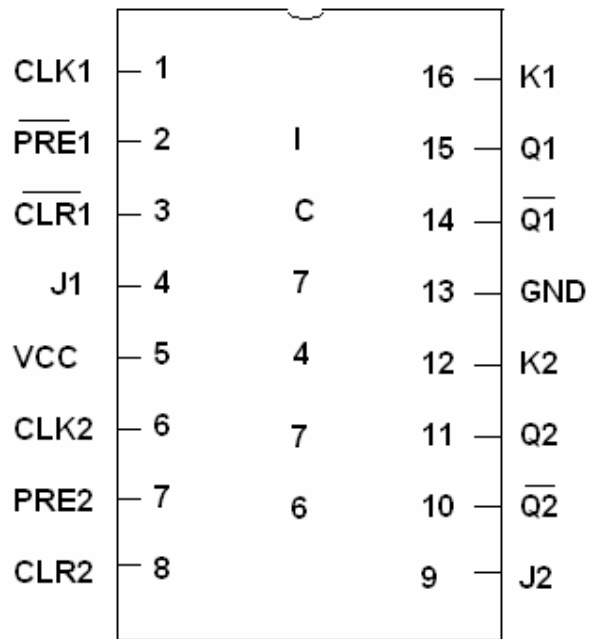

Logic Diagram For 4 Bit Ripple Counter:

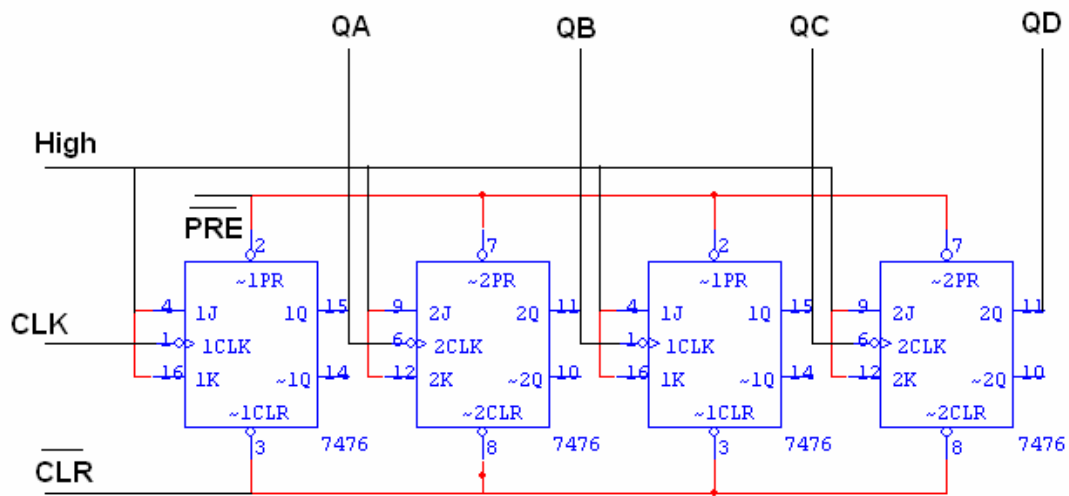

Truth Table

CLK	QA	QB	QC	QD
0	0	0	0	0
1	1	0	0	0
2	0	1	0	0
3	1	1	0	0
4	0	0	1	0
5	1	0	1	0
6	0	1	1	0
7	1	1	1	0
8	0	0	0	1
9	1	0	0	1
10	0	1	0	1
11	1	1	0	1
12	0	0	1	1
13	1	0	1	1
14	0	1	1	1
15	1	1	1	1

Logic Diagram for Mod - 10 Ripples Counter

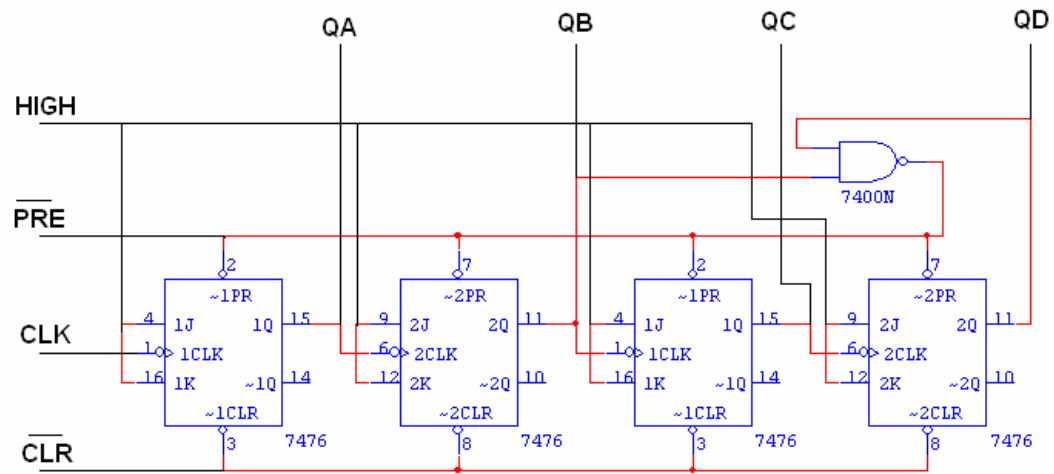

Truth Table

CLK	QA	QB	QC	QD
0	0	0	0	0
1	1	0	0	0
2	0	1	0	0
3	1	1	0	0
4	0	0	1	0
5	1	0	1	0
6	0	1	1	0
7	1	1	1	0
8	0	0	0	1
9	1	0	0	1
10	0	0	0	0

Logic Diagram for Mod - 12 Ripples Counter

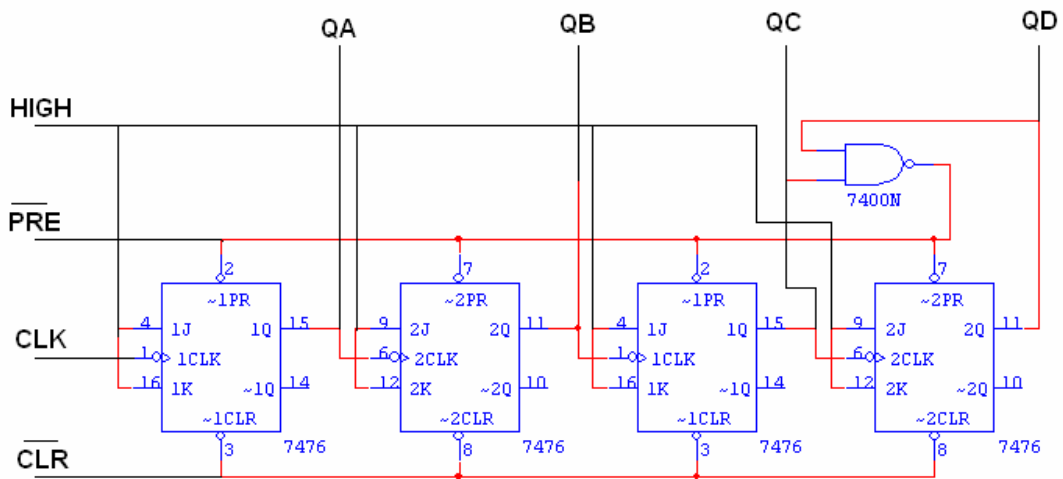

Truth Table

CLK	QA	QB	QC	QD
0	0	0	0	0
1	1	0	0	0
2	0	1	0	0
3	1	1	0	0
4	0	0	1	0
5	1	0	1	0
6	0	1	1	0
7	1	1	1	0
8	0	0	0	1
9	1	0	0	1
10	0	1	0	1
11	1	1	0	1
12	0	0	0	0

Procedure

- (i) Connections are given as per circuit diagram.
- (ii) Logical inputs are given as per circuit diagram.
- (iii) Observe the output and verify the truth table.